

# **H&S**

# **REAR UNLOAD**

# **POWER BOX**



## **WARNING**

**READ AND UNDERSTAND THIS  
MANUAL BEFORE OPERATING  
THIS EQUIPMENT.**

**UNSAFE OPERATION OR  
MAINTENANCE OF THIS  
EQUIPMENT CAN RESULT  
IN SERIOUS INJURY  
OR DEATH.**

## **OPERATOR'S MANUAL**

and

## **PARTS LIST**

3-11-09

Manufactured By  
**H&S MANUFACTURING CO., INC.**  
P.O. BOX 768 • (715) 387-3414 FAX (715) 384-5463  
MARSHFIELD, WISCONSIN 54449

**H&S**  
**REAR UNLOAD**  
**POWER BOX**  
**CONTENTS**

Warranty & Warranty Registration Card .....	1-2
Dealer Pre-Delivery & Delivery Checklist .....	3
Be Alert Symbol. ....	5
Explanation of Safety Signs .....	6
Warning - Danger Decals .....	7
Warning - Owner Must Read and Understand .....	8
Before Operation - Adjustments .....	9-10
Lubrication Guide .....	11
Field Operation - Rear Door Latches .....	12
Decal Location & Identification .....	13-14
Ordering Parts - About Improvements .....	14
Figure 1 - Light Assembly - Wiring Code - Description. ....	15
Figure 2 - Rear Unloading Assembly - Description. ....	16-17
Figure 3 - Box Component Parts - Description. ....	18-19
Figure 4 - Tie-Down .....	20
SPECIFICATIONS. ....	INSIDE BACK COVER

**AFTER COMPLETION, DEALER SHOULD REMOVE AND RETAIN FOR RECORDS**

**H&S  
DEALER PRE-DELIVERY CHECK LIST**

After the Power Box has been completely set-up, check to be certain it is in correct running order before delivering to the customer. The following is a list of points to inspect. Check off each item as you have made the proper adjustments and found the item operating satisfactorily.

- All Shields and Guards are in place and fastened.
- All Grease Fittings have been lubricated.  
See lubrication guide in this manual.
- All Mechanisms are operating trouble free.
- All Roller Chains are at proper tension.
- Apron Chains are adjusted properly.
- All Bolts and Fasteners are tight.
- All Decals are in place and legible.

\_\_\_\_\_  
(Dealer's Name)

\_\_\_\_\_  
Model Number

\_\_\_\_\_  
Serial Number

\_\_\_\_\_  
(Signature of Pre-Delivery Inspector)

\_\_\_\_\_  
(Inspection Date)

**DEALER DELIVERY CHECK LIST**

This check list that follows is an important reminder of valuable information that should be passed on to the customer at the time this Power Box is delivered.

Check off each item as you explain it to the customer.

This pre-delivery check list, when properly filled out and signed assures the customer that the pre-delivery service was satisfactorily performed.

- Explain to the customer that the pre-delivery inspection was made.
- Explain to the customer all the safety precautions they must exercise when operating this unit.
- Explain recommended loads for different types of materials.
- Explain to customer that regular lubrication is required for proper operation and long life of machine. Show customer the lubrication section of Owner's Manual.
- Give the customer Owner's Manual and make sure he reads and understands all operating and service instructions.
- Record Serial Number on Page 14 of this Manual.
- Have customer sign a completed "Warranty Registration," and mail it promptly.

Date Delivered \_\_\_\_\_

Dealer's Name \_\_\_\_\_

By \_\_\_\_\_

\_\_\_\_\_  
Signature of Original Buyer

Note: Warranty is not valid until warranty card is completed and returned to H&S Mfg. Co., Inc.

(Remove Dealers File Copy At Perforation)





**BE  
ALERT!**

**YOUR SAFETY  
IS INVOLVED.**

**THIS SYMBOL IS USED THROUGHOUT THIS BOOK WHENEVER YOUR PERSONAL SAFETY IS INVOLVED. TAKE TIME TO BE CAREFUL. REMEMBER: THE CAREFUL OPERATOR IS THE BEST OPERATOR. MOST ACCIDENTS ARE CAUSED BY HUMAN ERROR. CERTAIN PRECAUTIONS MUST BE OBSERVED TO PREVENT THE POSSIBILITY OF INJURY OR DAMAGE.**

**TRACTORS**

**This operator's manual uses the term "Tractor" when identifying the power source for the Rear Unload Power Box. However, the same safety and operating practices apply to other power sources.**

**H&S MANUFACTURING CO. INC.**

## RECOGNIZE SAFETY INFORMATION

This is the safety-alert symbol. When you see this symbol on your machine or in this manual, be alert to the potential for personal injury.

Follow recommended precautions and safe operating practices.



## UNDERSTAND SIGNAL WORDS

A signal word—DANGER, WARNING, or CAUTION—is used with the safety-alert symbol. DANGER identifies the most serious hazards.

Safety signs with signal word DANGER or WARNING are typically near specific hazards.

General precautions are listed on CAUTION safety signs.



## FOLLOW SAFETY INSTRUCTIONS

Carefully read all safety messages in this manual, and all safety signs on your machine. Follow all recommended precautions and safe operating procedures.

Keep signs in good condition. Immediately replace any missing or damaged signs.

**⚠ WARNING**

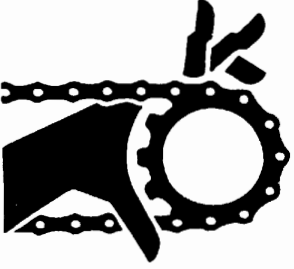

**DO NOT CLEAN OR WORK ON THIS MACHINE WITHOUT FIRST DISENGAGING POWER AND SHUTTING OFF TRACTOR ENGINE.**

1494J



**⚠ WARNING**

**DO NOT GO NEAR LEAKS**

- High pressure oil easily punctures skin causing serious injury, gangrene or death.
- If injured, seek emergency medical help. Immediate surgery is required to remove oil.
- Do not use finger or skin to check for leaks.
- Lower load or relieve hydraulic pressure before loosening fittings.

11599

**⚠ WARNING**



**DO NOT REMOVE SHIELDS MOVING PARTS INSIDE**

1494K



**⚠ WARNING**

**DO NOT REMOVE SHIELDS MOVING PARTS INSIDE**

1494B

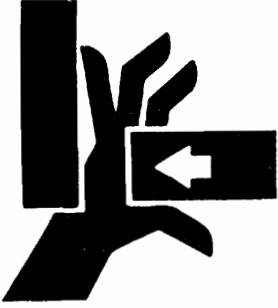

**⚠ WARNING**

**STAY CLEAR MOVING PARTS UNDER THIS AREA**

1494C

**⚠ WARNING!**



**KEEP CHILDREN AWAY AT ALL TIMES!**

2495

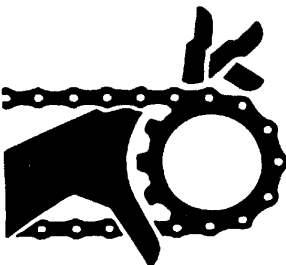

**⚠ WARNING**

**DO NOT OPERATE THIS EQUIPMENT IF THIS DECAL IS EXPOSED. REPLACE SAFETY SHIELDS.**

1494A

# H&S REAR UNLOAD POWER BOX



# W A R N I N G

## TO PREVENT SERIOUS INJURY OR DEATH

BEFORE YOU ATTEMPT TO OPERATE THIS EQUIPMENT, READ AND STUDY THE FOLLOWING INFORMATION. IN ADDITION, MAKE SURE THAT EVERY INDIVIDUAL WHO OPERATES OR WORKS WITH THIS EQUIPMENT, WHETHER FAMILY MEMBER OR EMPLOYEE, IS FAMILIAR WITH THESE SAFETY PRECAUTIONS.

KNOW HOW TO STOP UNLOADING MECHANISM BEFORE STARTING IT.

If the machine becomes clogged, disengage tractor hydraulics, stop the tractor engine and allow all mechanisms to stop before cleaning or working on the machine.

**DO NOT** attempt to perform maintenance or repair with tractor running and hydraulics hooked to the tractor.

**DO NOT** step up on machine at any time.

**DO NOT** get off the tractor when box is in operation. Operator position is in the tractor seat.

**DO NOT** ALLOW PERSONNEL OTHER THAN THE QUALIFIED OPERATOR NEAR THE MACHINE.

**DO NOT** allow minors to operate or be near the machine.

**STAY CLEAR** of rear of Power Box at all times.

**DO NOT** clean, adjust, or lubricate the machine when any part is in operation.

**BE SURE** the machine is clear of people, tools, and other objects before engaging tractor hydraulics.

**NEVER** start power box until all guards and safety shields are secured in place.

**STAY CLEAR** of hydraulic lines, they may be under extreme pressure or heat.

Loose or floppy clothing should not be worn by the operator.

**CAUTION** – BEWARE OF LOW ELECTRICAL WIRES.

H&S Mfg. Co. always takes the operator and his safety into consideration and guards exposed moving parts for his protection. However, some areas cannot be guarded or shielded in order to assure proper operation. In addition, the operators manual and decals on the machine itself warn you of further danger and should be read and observed closely.

## Study The Above Safety Rules

## ATTENTION - BE ALERT - YOUR SAFETY IS INVOLVED



# BEFORE OPERATION

Check entire unit carefully before first operation. Tighten bolts, set screws, and chains which might have come loose in handling. Lubricate as explained in the lubrication guide. Run the unloading mechanism for several minutes. This will serve as a break-in and as a check that all parts are assembled and lubricated properly. Successful operation will be achieved by periodic adjustments and experience of the operator. Make sure to read and understand the main feeder apron adjustments.

Located on the front of the Power Box is a convenient hanger (Item A) for the hydraulic hoses. When the Power Box is not being unloaded, hoses should be securely wrapped around this holder, with ends inserted into Block Holder (Item B).

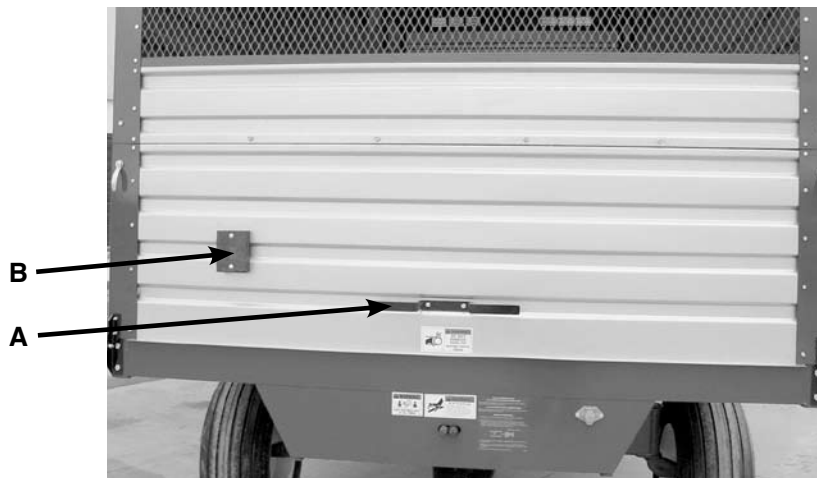

**C**

WHEN TRANSPORTING ON THE HIGHWAY OR ROADS, PLACE SMV SIGN IN SOCKET (D) PROVIDED AND REGULARLY CLEAN THE REFLECTIVE TAPE (C) AT THE REAR OF THE POWER BOX.

**D**

NOTE: Obey all state and local laws, concerning towed equipment, on public roads.

For light information (See Page 15).

# ⚠️ WARNING

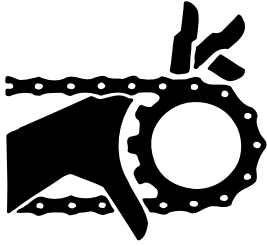

**DO NOT CLEAN  
OR WORK ON THIS  
MACHINE WITHOUT  
FIRST DISENGAGING  
POWER AND  
SHUTTING OFF  
TRACTOR ENGINE.**

## MAIN FEEDER APRON ADJUSTMENT

Main feeder apron adjustment bolts are located behind the convenient access door located in the bottom portion of front gate. Remove handle nuts (A) to open access door and swing door downward.

All apron chains must be taken up evenly before you use the power box. Check again after the first few loads. The Main Feeder Aprons should be at proper tension at all times. Tighten the full threaded bolts (B) to adjust aprons. Aprons are properly adjusted when two Cross Slats, or about three feet of chain lift off the Chain Return Slides from the front of the box. Maintain this tension when operating the box.

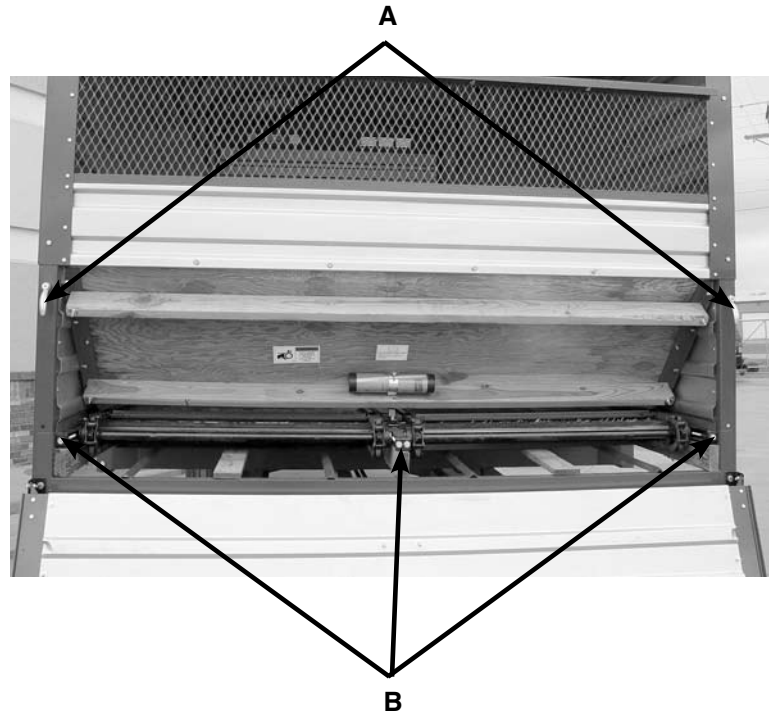

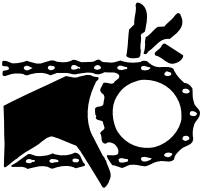
	<b>⚠️ WARNING</b>
	<b>ROTATING PARTS CLOSE ACCESS DOOR BEFORE OPERATING BOX</b>

### PRIMARY DRIVE

The roller chain between the hydraulic motor and large reduction sprocket is adjusted by loosening the four bolts holding the motor. Slide motor downward in slots in panel until roller chain is tight. Retighten four bolts holding hydraulic motor.

### FINAL DRIVE

A roller type chain tightener is provided to adjust tension on the roller chain between drive sprocket and sprocket on main apron drive shaft. Chain is properly adjusted when there is slight deflection at the center of the chain.

**TIGHTENER**

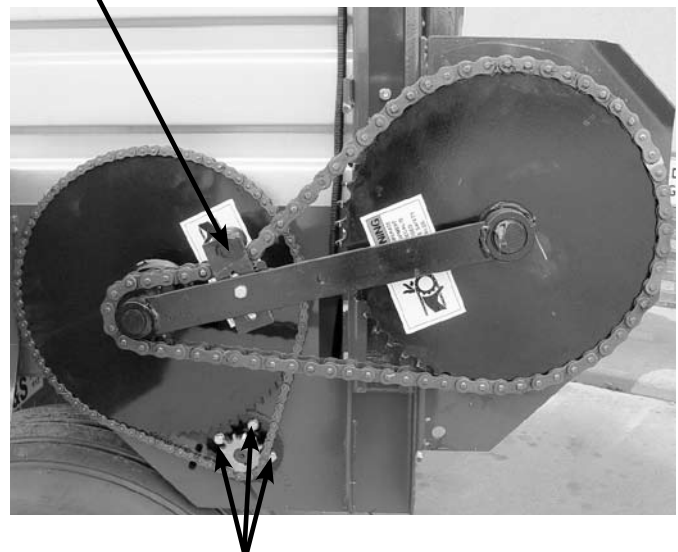

**MOTOR MOUNTING BOLTS**

# LUBRICATION GUIDE



The operator should become familiar with all lubrication points and establish a systematic routine to insure complete and quick lubrication of the machine.

## DRIVE CHAINS

Lubricate the drive chains with a light machine oil. Keep chains aligned with sprockets. This will lengthen the life of the sprockets and chain. Lubricate chains often.

## GREASE ZERKS

There are nine (9) grease fittings on your new H&S REAR UNLOAD POWER BOX. Grease daily during normal use and before and after storage. Use a good grade of high quality grease.

Listed below is location and quantity of zerks.

- A. (4) one on each main apron front idler sprocket.
- B. (3) one on left hand, center, and right hand rear main apron drive shaft brackets.
- C. (1) one on gear reduction sprocket at left rear of box.
- D. (1) one on drive shaft end of brace for rear main apron drive shaft.



A



B

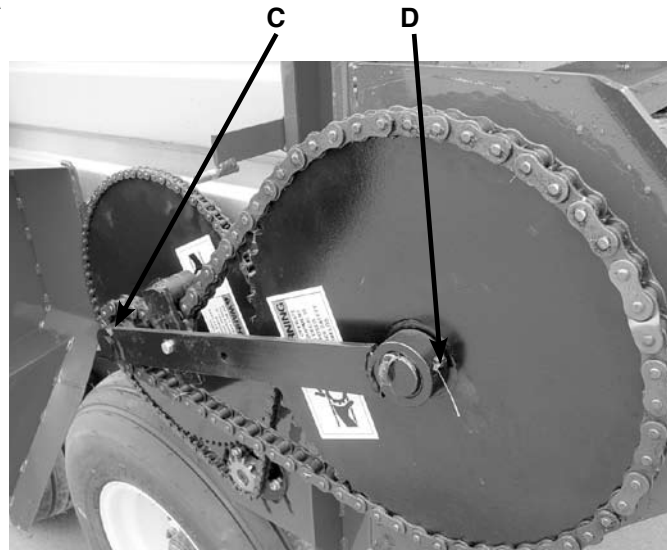

C

D

# FIELD OPERATION OF REAR UNLOAD POWER BOX

After you have idled your H&S Rear Unload Power Box for several minutes, and checked it over thoroughly as suggested in earlier recommendations, and have properly adjusted and lubricated it, you are ready to place your Power Box into operation.

## UNLOADING

1. Park Power Box on level ground whenever possible during unloading.
2. Connect hydraulic hoses from Power Box to the tractor.
3. With operator in the tractor seat and all others well clear of Power Box, engage the tractor hydraulics.  
**NOTE:** Rear unload operates in only one direction. If tractor hydraulic system stalls, check for obstruction, reverse the lever on the tractor or switch the hydraulic hoses at the ports on the tractor. If stalling persists, the problem may be insufficient tractor hydraulic pressure.

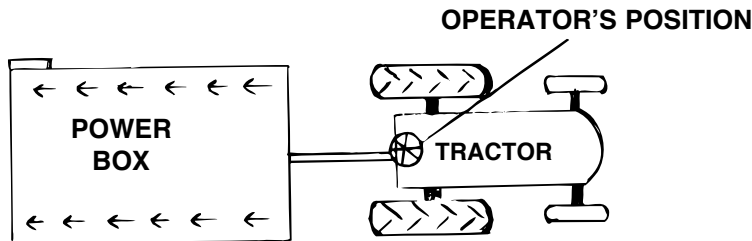

4. During unloading, move the Power Box forward to allow material to fall away from rear of box.
5. When box is empty, disengage tractor hydraulics, disconnect hoses from tractor, and securely wrap hoses on convenient holder on the front of the Power Box.
6. Check rear door to make sure it is securely latched.

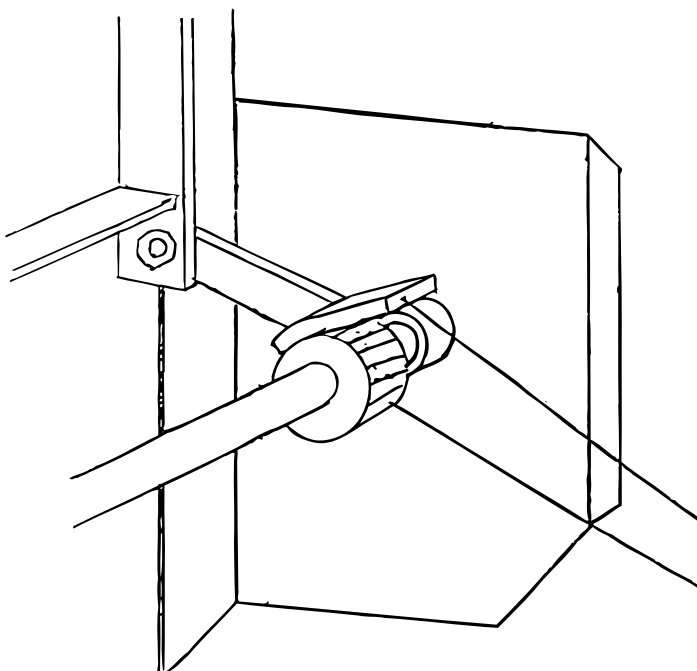

## REAR DOOR LATCHES

Located at the bottom left and right hand side of the rear door are the door latches. These latches lock against knurled gears on rear drive shaft to hold door closed when loading Rear Unload Power Box. When tractor hydraulics are activated and rear drive shaft turns, knurled gears flip latches open to allow rear door to swing free. Upon completion of unloading check rear door to insure that door latches are securely in place for next load.

DOOR LATCH

KNURLED GEAR

# DECAL LOCATION

Your H&S Rear Unload Power Box was manufactured with operator safety in mind. Located on the Power Box are various decals to aid in operation, and warn of danger or caution areas. Pay close attention to all the decals on your Power Box.



**DO NOT REMOVE ANY OF THESE DECALS. IF DECALS ARE LOST, DAMAGED, OR IF THE POWER BOX IS REPAINTED, REPLACE DECALS. REMEMBER: DECALS ARE FOR YOUR PROTECTION AND INFORMATION.**

Listed below are the decals on your Rear Unload Power Box. These decals may be ordered individually by part number or by ordering complete set.

ITEM	PART NO.	DESCRIPTION
A	71293	Field Operation
B		(2) H&S Metal Sign (12"x 24")
C	1494C	(4) Warning - Moving Parts Under
D	106-3185	Serial Number
E	1494J	Warning - Do Not Clean or Work
F	1494K	Warning - Do Not Remove Shields
G		(2) Red Reflector
H	1494A	(3) Warning - Do Not Operate (P.14)
I	2495	Warning - Keep Children Away
J	11599	Warning - Do Not Go Near Leaks
K		Amber Reflector
L	1494B	Warning - Do Not Remove Shields
M	93366	Manual Holder
	42804-PB	Complete Set of Decals
Paint - H&S Red		
	ZX21	Gallon
	ZX22	Quart
	ZX23	Pint

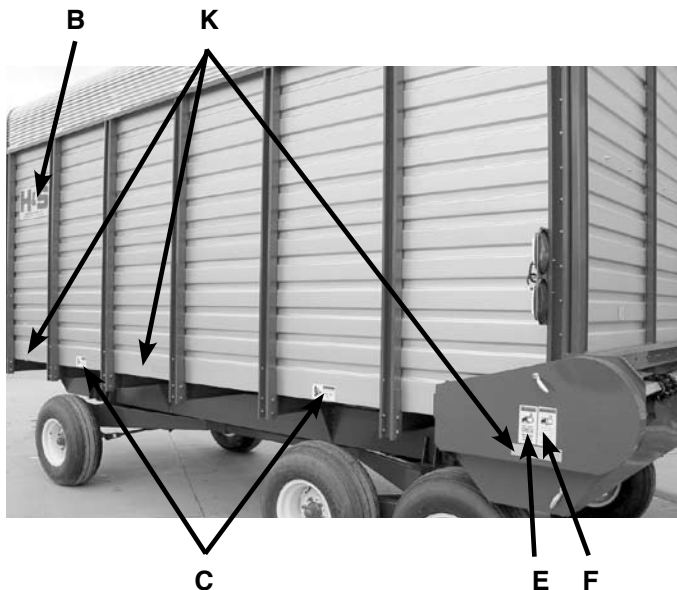
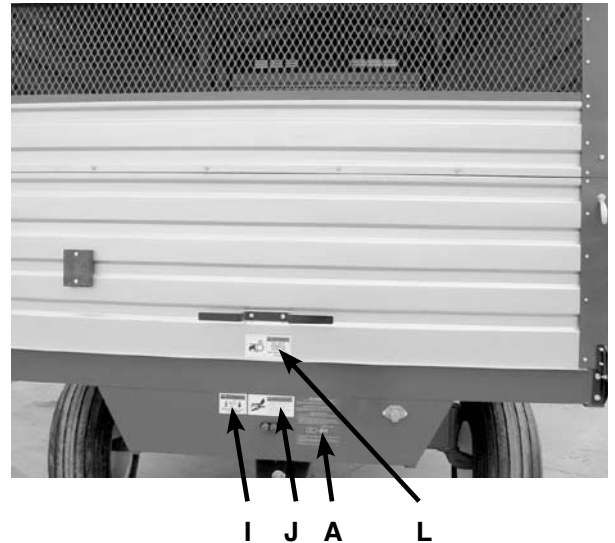

*(Continued on Page 14)*

## DECAL LOCATION (Continued)

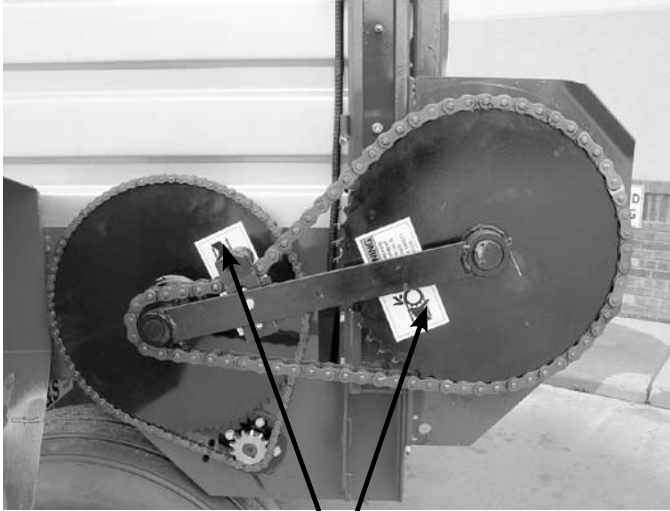

H



H

M

---

## INSTRUCTIONS FOR ORDERING PARTS

All service parts should be ordered through your authorized H&S Dealer. He will be able to give you faster service if you will provide him with the following:

1. Model & Serial Number – Both can be located on the rear, left side of your unit.
2. All reference to left or right apply to the machine as viewed from the rear.
3. Parts should not be ordered from illustration only. Please order by complete parts numbers.
4. If your dealer has to order parts - give shipping instructions:  
VIA truck - large pieces (please specify local truck lines)  
VIA United Parcel Service (include full address)

<b>H&amp;S MFG. CO. INC.</b>	
MARSHFIELD, WIS.	
MOD. NO.	<input type="text"/>
SER. NO.	<input type="text"/>
DESCR.	<input type="text"/>

PLEASE RECORD NUMBERS FOR YOUR UNIT FOR QUICK REFERENCE

### ABOUT IMPROVEMENTS

H&S MFG. CO. IS CONTINUALLY STRIVING TO IMPROVE ITS' PRODUCTS.

We must therefore, reserve the right to make improvements or changes whenever it becomes practical to do so, without incurring any obligation to make changes or additions to the equipment previously sold.

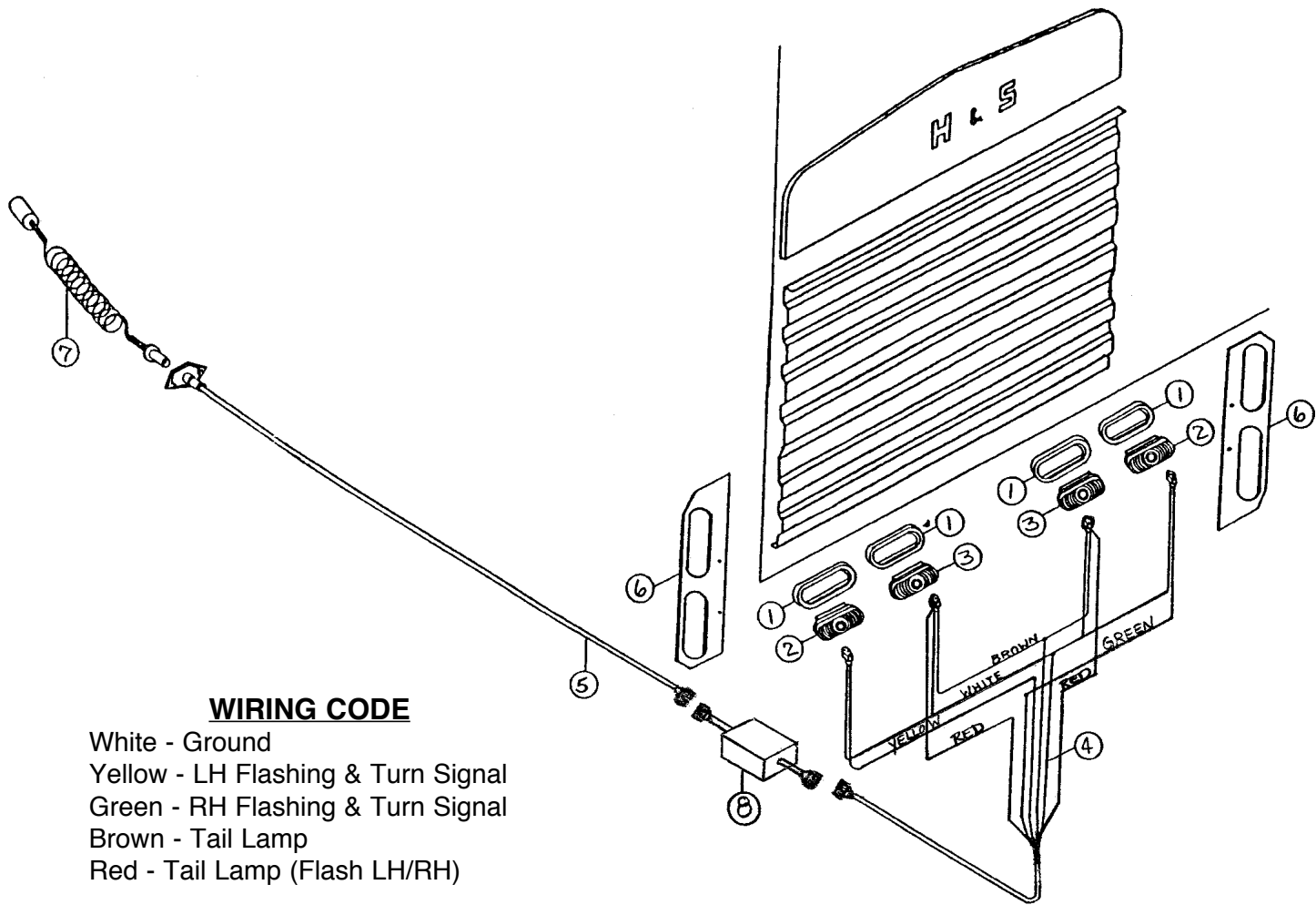

**WIRING CODE**

- White - Ground
- Yellow - LH Flashing & Turn Signal
- Green - RH Flashing & Turn Signal
- Brown - Tail Lamp
- Red - Tail Lamp (Flash LH/RH)

**FIGURE 1  
REAR UNLOAD POWER BOX  
LIGHTING ASSEMBLY**

ITEM	PART NO.	DESCRIPTION
1.	S308	Rubber Light Mount
2.	S309	Amber Light
3.	S310	Red Light
4.	PB232	Light Harness (6-WIRE)
5.	S443	18' Longitudinal Cord (4-WIRE)
	S442	20' Longitudinal Cord (4-WIRE)
6.	PB111	Taillight Brackets
7.	S317	Optional Tractor Cord
8.	S441	Light Module
*	PB237	18' Complete Light Assembly
		Less Optional Tractor Cord
*	PB238	20' Complete Light Assembly
		Less Optional Tractor Cord

**NOTE:** \* (Means Not Shown)

FIGURE 2

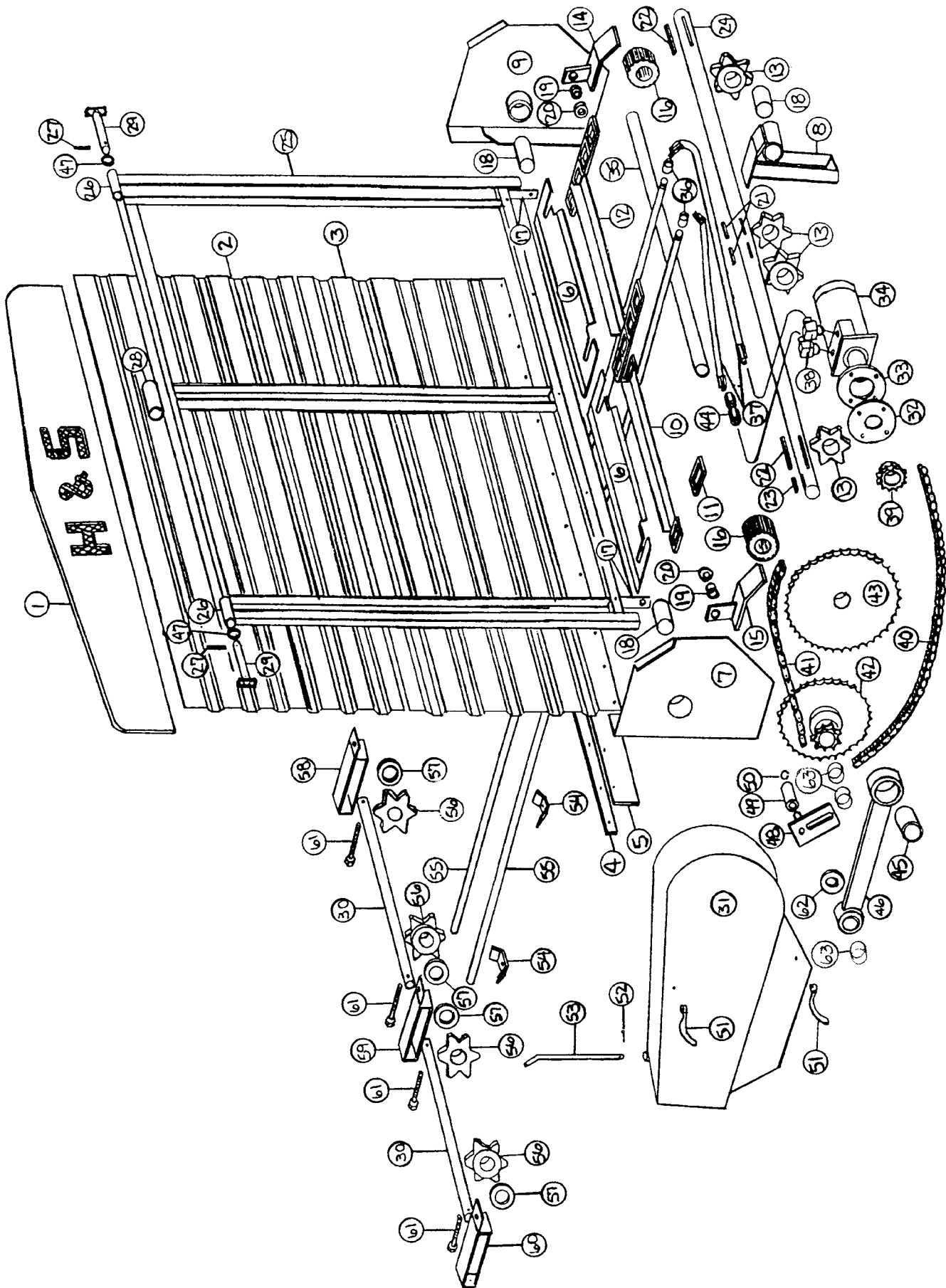



**FIGURE 2  
REAR UNLOAD ASSEMBLY**

ITEM	BOX SIZE		DESCRIPTION
	18'	20'	
1.	PB72	"	Back Door Top Panel
2.	PB23	"	Back Door Top Steel
3.	PB24	"	Back Door Bottom Steel
4.	S288	"	Seal Strap
5.	PB54	"	Rubber Seal
6.	PB74	"	Drive Shaft Panel
7.	PB80	"	LH Drive Shaft Mount
8.	PB81	"	Center Bearing Bracket
9.	PB82	"	RH Drive Shaft Mount
10.	S233	"	667H Pintle Slat W/Attachment Links
11.	11S51	"	667H Pintle Connector Links
11A.	11S50	"	667H Pintle Attachment Links RH or LH
12.	PB77	PB78	667H Complete Pintle Apron
13.	23N122	"	Drive Shaft Sprockets
14.	PB57	"	Latch Bracket RH
15.	PB58	"	Latch Bracket LH
16.	PB83	"	Latch Sprocket
17.	PB60	"	Rear Door Latch Mount
18.	23N17	"	Drive Shaft Bushing
19.	PB61	"	Latch Pivot
20.	A34	"	Latch Washer
21.	PB87	"	Key 3/8" x 2" Square
22.	PB133	"	Key 3/8" x4-3/8" Square
23.	PB136	"	Key 3/8" x 2 Square w/Round Ends
24.	PB194	"	Drive Shaft
25.	PB73	"	Back Door Framework
26.	PB65	"	Hinge
27.	3G22	"	Expansion Pin
28.	PB66	"	Guard
29.	PB129	"	Hinge Pin
30.	S63	"	Idler Shaft
31.	PB99	"	Rear Drive Shield
32.	PB260	"	Hydraulic Motor Mount Washer
33.	PB261	"	Hydraulic Motor Mount Spacer
34.	DF1	"	Hydraulic Motor
35.	PB107	"	Idler Shaft
36.	PB105	"	1/2" Pipe Coupling
37.	PB41	"	Hydraulic Hose 60"
38.	HE58	"	Elbow
39.	PB235	"	Sprocket (2000 Series)
40.	PB97	"	#50 Chain 90 Pitches
41.	PB114	"	#80 Chain 73 Pitches
42.	PB95	"	11T-84T Sprocket
43.	PB94	"	52T Sprocket
44.	DF18	"	Check Valve
45.	S41	"	Bushing 1-3/4" OD x 1-1/2" ID x 1-1/8"
46.	PB98	"	Drive Shaft Brace
47.	PB130	"	Collar
48.	L10R35	"	Chain Tightener Bracket
49.	23N238	"	Roller Chain Tightener
50.	10R32	"	Snap Ring
51.	S192	"	Handle
52.	T37	"	Cotter Pin
53.	PB100	"	Hinge Pin
54.	23N67	"	Hose Holder
55.	PB18	PB102	Hydraulic Pipe
56.	S60	"	Idler Sprocket
57.	S61	"	Idler Spacer
58.	S62	"	RH Idler Bracket
59.	S64	"	Center Idler Bracket
60.	S65	"	LH Idler Bracket
61.	A7	"	Idler Bolt
62.	PB141	"	Washer
63.	PB108	"	Bushing 1-1/4" IDx1-1/2"ODx1-3/4"



**FIGURE 3  
BOX AND COMPONENT PARTS**

ITEM	BOX SIZE		DESCRIPTION
	18'	20'	
1.	S147	S297	Top Rail
2.	S144	S298	Top Rail
3.	*S150PB	**S299PB	Side Steel
4.	S153	S300	Roof Steel
5.	ST61	"	Branch Guard
6.	ST60	"	Roof Support
7.	ST49	"	Side Stake
8.	PB67	"	LH Rear Stake
9.	PB68	"	RH Rear Stake
10.	S164	S301	Apron Chain Center Spacer
11.	S167	S302	Apron Chain Side Spacer
12.	S170	S303	Floor Assembly
13.	S269	"	Stake Pocket Front
14.	ST50	"	RH Front Stake
14A.	ST51	"	LH Front Stake
15.	PB71	"	Brace
16.	PB12	"	Door Hinge Bracket
17.	PB29	"	Hydraulic Hose Holder
18.	S268	"	Stake Pocket
19.	PB70	"	Front Door Bottom Steel
20.	PB43	"	Top Rail
21.	PB19	"	Power Box Shelf Angle RH
22.	PB20	"	Power Box Shelf Angle LH
23.	PB69	"	Expanded Metal Screen
24.	PB131	"	Front LH Side Piece
25.	PB132	"	Front RH Side Piece
26.	S191	"	Brace
27.	S192	"	Handle Nut
28.	S193	"	RH Hinge Top Piece
29.	S194	"	RH Hinge Bottom Piece
30.	S195	"	RH Side Piece
31.	S196	"	LH Side Piece
32.	S197	"	Back Door Tailgate Section
33.	S198	"	LH Hinge Bottom Piece
34.	S199	"	LH Hinge Top Piece
35.	PB42	"	Front Slant Panel
36.	JB105	"	Hose Coupling Holder
37.	S236	"	Rear Roof Support
38.	S399	"	Rear Branch Guard
39.	S522	"	Manual Holder
*	CHM38	"	Plug Storage

\*S150PB - 214-1/2" x 41"

\*\*S299PB - 238-1/2" x 41"

**NOTE:** \* (Means Not Shown)

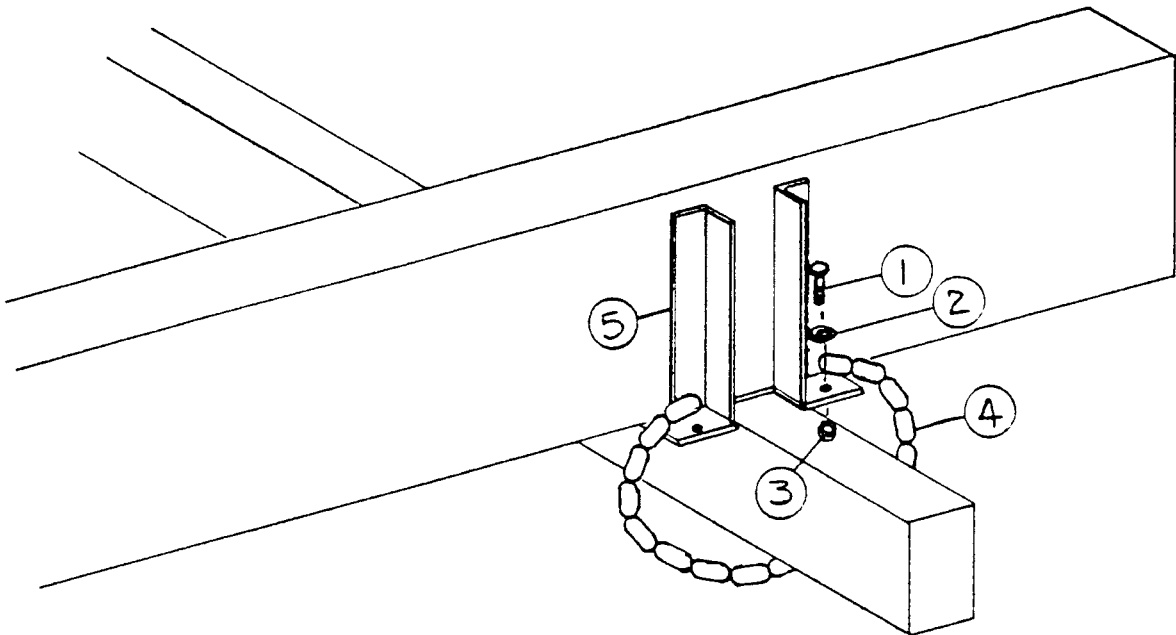

**FIGURE 4  
TIE DOWN KIT**

<b>ITEM</b>	<b>PART NO.</b>	<b>DESCRIPTION</b>
1.	12V45	1/2" x 1-1/2" GR.5 Bolt
2.	K68	1/2" Flat Washer
3.	R11	1/2" Top Lock Nut GR.5
4.	S322	1/4" Chain 30-1/4" Long
5.	S323	Tie Down Bracket
6.	T9B	Tie Down Kit - Complete

---

## H&S REAR UNLOAD POWER BOX

Your new H&S Power Box has been manufactured of the finest quality materials and components. The performance you get from your machine is largely dependent upon how well you read and understand this manual and apply this knowledge. There is a right and a wrong way to do everything. Please do not assume that you know how to operate and maintain your Power Box before reading this manual carefully. Keep this manual available for ready reference.

### POWER BOX SPECIFICATIONS

<b>POWER</b> .....	Hydraulic Drive
<b>FEEDER APRON DRIVE</b> .....	Roller Chain and Sprocket
<b>UNLOADING SPEED</b> .....	Depends on Tractor Hydraulic System
<b>MAIN APRONS</b> .....	4 Chains—667H Pintle
<b>INSIDE LENGTH</b> .....	18' & 20'
<b>OVERALL LENGTH</b> .....	19'3" & 21'3"
<b>OVERALL WIDTH</b> .....	98"
<b>OVERALL HEIGHT</b> .....	117"

#### NOTE

Determine right or left side of unit by viewing it from the rear. If instructions or parts lists call for hardened bolts, they are identified with three lines or marks on the head.

## H&S MANUFACTURING CO. INC.

2608 S. Hume Ave.  
P.O. Box 768 - Telephone (715) 387-3414  
FAX (715) 384-5463  
MARSHFIELD, WI 54449



H&S WAREHOUSE Rt. #5 and 76  
P.O. Box 1260 - Telephone (716) 736-7595  
FAX (716) 736-7596  
RIPLEY, NY 14775

# **H&S MFG. CO.**

products approved

for the

## **FEMA**

# **SEAL OF QUALITY**

